



Общество с ограниченной ответственностью

Системы Пожаротушения



Generator of fire extinguishing aerosol  
(portable)

GAOP-I-2,8-031-016

TU 4854-015-69229785-2012



**SureFIRE**  
EXTINGUISHER

«TOR 1700 (OP)»

«TOR 2800 (OP)»

«TOR 3500 (OP)»

PASSPORT and OPERATION MANUAL

Sent-Petersburg

## 1. DESIGNATION

Portable generators of fire extinguishing aerosol «Tor 1700(OP)» «Tor 2800(OP)» «Tor 3500(OP)» (further “generators”) with circle aerosol discharge are designed for suppressing fires and ignitions of Subclass A2 and Class B, and for localization of fires and ignitions of Subclass A1 in conditionally hermetic volumes inclusive of rooms with electric cables and equipment under tension with the voltage parameter of up to 110 KV.

The predominant sphere of the generators application is rooms in production, office, storage and residential buildings as well as on railway and motor transport, sea craft and river boats, etc.

The generators belong to the class of portable extinguishers and contains no ozone depletion substances. Class of dangerous goods is – 4.1, UN number - 3178.

## 2. BASIC TECHNICAL CHARACTERISTICS

№	Parameters, units	Value		
		TOR 1700(ОП)	TOR 2800(ОП)	TOR 3500(ОП)
1	Mass of assembled generator, kg	3,8±0,15	5,4±0,2	6,9±0,2
2	Mass of aerosol forming compound charge (KEP) , kg	1,7±0,1	2,8±0,15	3,5±0,2
3	Operation temperature , °C	- 60 °C + 60 °C		
4	Fire extinguishing capability (extinguishing application density) , kg/ m <sup>3</sup> - for fires of Class B - for fires of Subclass A2	0,028 0,022		
5	Maximum volume of conditionally hermetic rooms where one generator suppresses the ignition of a standardized fire according to GOST R 53285-2009, m <sup>3</sup> - for Class B - for Subclass A2	60 77	100 127	125 160
6	Duration of fire extinguishing aerosol discharge at the ambient temperatures, sec: - 60 °C + 20 °C + 50 °C	11 ± 2 10 ± 2 9 ± 2	18 ± 3,0 16 ± 3,0 14 ± 3,0	20 ± 3 18 ± 3 16 ± 3

7	Time of the generator start delay, sec	7 ÷ 10		
8	Workable position of a generator after it is thrown	horizontal		
9	. Overall dimensions , mm, not more than: <ul style="list-style-type: none"> <li>• height - H</li> <li>• diameter - D</li> <li>• width – B</li> </ul>	75 ± 2,0 240 ± 2,0 291 ± 5,0	110 ± 2,0 240 ± 2,0 294 ± 5,0	123 ± 2,0 240 ± 2,0 294 ± 5,0
11	Probability of the generator's free operation fault between periodical inspections of the generator conducted in time of not less than once per three years	0,95		
12	Length of the discharged aerosol stream where the under mentioned temperature reaches, m: <ul style="list-style-type: none"> <li>• 75°C</li> <li>• 200°C</li> <li>• 400° C</li> </ul>	not more than 0,75 not more than 0,28 not more than 0,14		
13	Time of the generator self actuation by the influence on it of a standardized fire 34B, min, not more than	6		
14	Maximum temperature of the generators canister in the place of its contact with the bearing area after the generators operation	not more than 150 °C		
15	Service life: - for generator - for starting unit URP-T (replacement in each 5 years)	10 лет		

### 3. DELIVERY SET

The delivery set includes:

1. Generator - 1 pc;
2. Starting unit – 1 pc;
3. Technical passport and operation manual - 1 pc;
4. Package.

### 4. CONSTRUCTION and OPERATION PRINCIPLE

The generator «Tor 2800 (OP)» (picture 1) consists of a case (1), where aerosol forming compound charges are placed (7). The charges are fixed in the

case with the help of a protective-strengthening composition (10). Between the semi-cases a manual starting unit (20) is put which has a safety cap (3) and a rip cord (4). The semi-cases are bounded to each other by fixture elements (11). The aerosol outflow occurs through nozzle holes (8), formed by stamped hollows in the flanging of the semi-cases and evenly distributed on the perimeter of the case. On one of the semi-cases there is a handle (9) for the generator transfer and throwing.

The storage and transportation of the generator is fulfilled without a manual starting unit. The generator preparation for operation is conducted with putting the manual starting unit into the bush (5) between the semi-cases.

For the generator start up one should put off a safety cap and throw a rip cord. The manual starting unit assures the generator operation delay for 7-10 sec., necessary for the safety throwing of the generator into the protected room.

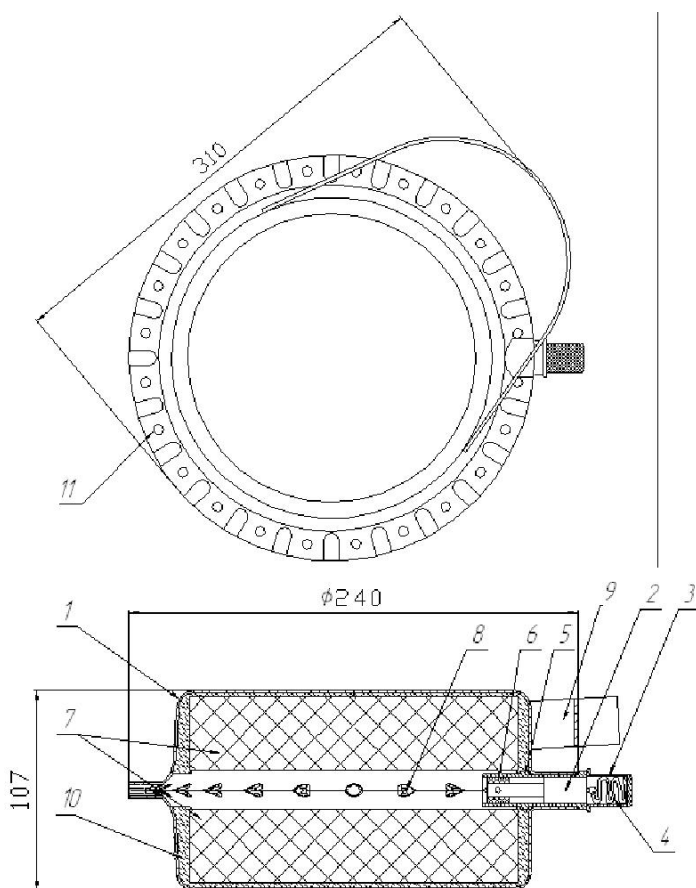

- |                              |                                       |
|------------------------------|---------------------------------------|
| 1 - корпус генератора        | 7 - заряд аэрозольобразующего состава |
| 2 - устройство ручного пуска | 8 - соляные отверстия                 |
| 3 - защитный колпачок        | 9 - ручка                             |
| 4 - вытяжной шнур            | 10 - защитно-крепящий слой            |
| 5 - втулка                   | 11 - крепежные элементы               |
| 6 - усиливающая шашка        |                                       |

Picture 1

## **5. RECOMMENDATIONS for USE**

It is recommended that the generators «Tor 2800 (OP)» should be used as initial fire suppression means for extinguishing fires in conditionally hermetic rooms (where the summary area of the open apertures is not more than  $0,001 \text{ m}^{-1}$  of the room volume according to GOST R 53285-2009) by workers of fire brigades and other personnel acquainted with the instructions on the use of such generators.

During extinguishing fires in bigger rooms for making essential aerosol extinguishing density the number of simultaneously thrown generators should be proportionally increased with truncation into a bigger side. At the protection of the room by some generators one should make minimal intervals in the generators throwing.

If the room has open apertures because of which the room is not considered to be conditionally hermetic or there is a ventilation installation in the room the effectiveness of the generators use reduces. In this case one should increase the number of the thrown generators and take measures for limiting of air change by closing windows, doors, manholes etc. and by switching off the ventilator.

The throw of the generators is made as far as possible on a free area in such a way that the generators can lay flat on the surface (floor) and the outflow of the aerosol from the nozzle holes effects unimpeded.

The generators «Tor 2800 (OP)» are not designated for extinguishing fires on open territories.

The operative position of the generator after its throwing into a seat of fire is horizontal on the upper or lower surface of the generator.

## **6. SAFETY MEASURES**

The personnel admitted to the operation with the generators should learn this manual, instructional inscriptions on the case (labels) and observe their requirements.

At time of a generator start it must be guaranteed that no people are present in the high temperature zone (more than  $75^{\circ}\text{C}$ ) of the aerosol stream. Before a generator start the people should be evacuated from the room where a fire has occurred. It is permitted for the people to come into the room again only after the ventilation of the room.

The fire extinguishing aerosol is a low-toxic product that in the fire extinguishing density is classified as low-hazard. It is not classified as dangerous for the objects of the environment. In case of aerosol particles getting into eyes, there can be the eyes irritation and chemosis. The eyes shall be washed with a large amount of water.

If it is necessary to conduct urgent works during ventilation one should use personal protection equipment for respiratory apparatus.

The amount and composition of the main products produced at a generator operation:

In % of volume fraction:

H <sub>2</sub>	CO <sub>2</sub>	H <sub>2</sub> O	CH <sub>4</sub>	N <sub>2</sub>	CO
0,00264	0,1595	0,3609	0,0522	0,4246	0,0000049

In % of mass fraction (solid substances):

Fe <sub>3</sub> O <sub>4</sub>	K <sub>2</sub> CO <sub>3</sub>	C
0,0010	0,4811	0,0598

The solid substances of the fire extinguishing aerosol sank of the open surfaces are taken away with the help of a dust cleaner, brush, damp rags and washed off by water. During cleaning one should use personal protection equipment for respiratory apparatus (breather or gauze bandage). In case of aerosol particles getting into eyes the eyes shall be washed with a large amount of water.

The maximum temperature in the area where the generator contacts the floor during operation and after it doesn't exceed 150 °C.

## **ATTENTION!**

**After the starting unit has been put into the generator any mechanical actions should be avoided for excluding casual start up.**

**After the rip cord has been pulled out the generator should be thrown immediately. In case of a casual start up the generator should be thrown immediately in a place safety for people better on an open territory.**

**It is not allowed:**

- **To conduct welding works, smoke and use open fire at a distance of not closer than 25 m from the generator.**
- **To take off the safety cap if there is no need to operate a generator.**
- **To operate generators in the rooms where people are present and on evacuation ways.**

## 7. STORAGE and TRANSPORTATION

Storage warehouse of generators is performed in the factory package in enclosed spaces at ambient temperature from  $-60^{\circ}\text{C}$  up to  $+50^{\pm 8^{\circ}}\text{C}$  and atmospheric moisture capacity up to 80% in the absence of corrosive medium.

It is permitted to pile the packages with generators in not more than three stacks.

The generators can be transported in the factory packages by any transport means. The transportation by air should be done in accordance with the existing rules for transportation of class 4.1 dangerous goods.

Generators fitted with starting units should be storage in special places with other fire extinguishing means. They should be protected from mechanical actions.

The generators should be under strict stocktaking and non-admission of accidental people for operation with them.

## 8. WARRANTY

10.1. The manufacturer guarantees that the generator conforms to the requirements of TU 4854-015-69229785-2012 provided the conditions of transportation, storage and operation of the generators are complied with.

10.2. The generator service life - 10 years.

10.3. Warranty period - 1 year from the generator's manufacture date provided the conditions of transportation, storage and operation of the generators are complied with.

## 9. NOTICE of EXCEPTANCE

The generator of fire extinguishing aerosol "Tor 2800 (OP)"  
serial № \_\_\_\_\_, complies with technical requirements TU

4854-015-69229785-2012 and is fit for operation. Date

of issue « \_\_\_\_\_ » \_\_\_\_\_ 20\_\_ г.

Signature \_\_\_\_\_

Stamp

## 10. NOTICE of SELLER

Date of sale «\_\_\_\_\_» \_\_\_\_\_ 20\_\_ г.

The seller name \_\_\_\_\_

---

Signature \_\_\_\_\_

Stamp

The manufacturer  
"Fire extinguishing systems"  
196641, Sent-Petersburg, Doroga onto Metallostroy str. 9-6  
Tel.: (812) 676-70-44, 676-70-45  
mail@intef.spb.ru

On the exclusive agreement  
for «Pojtehexport» Ltd.  
6, Uchinskaya str., Moscow, Russia, 127411  
Тел.: (495) 789-64-14, 484-24-20, Факс: (495) 789-64-  
14 [www.epotos.com](http://www.epotos.com)  
[pojtehexport@mail.ru](mailto:pojtehexport@mail.ru)